

TRAILBOSS

Towbar Fitting Instructions To Suit **VOLVO XC60 DZ SERIES** Part Number **QTVO009L** Rating **2000/150 kg**

PLACE THESE INSTRUCTIONS IN THE VEHICLE'S GLOVEBOX AFTER INSTALLATION IS COMPLETED

WARNING:

1. Do not, drill, cut, weld or otherwise modify the tow bar.
2. If you are using electric welding on a motor vehicle, **always** check that the vehicle is not equipped with electronic engine or instrument management equipment. Failure to do so could **destroy** any onboard computers. If in doubt, check with the vehicle's manufacturer.
3. The high tensile fasteners supplied with this product were used to achieve the specified rating. If replacement is required ensure that fasteners of the same rating & quality are used. Contact an authorised **Trailboss** dealer if further information is required.
4. If TBM is used in inverted position tow ball may make contact with rear tailgate when lowered, which could cause damage.

General:

1. Ensure all hardware items have been included refer to assembly diagram.
2. It is recommended that the instructions are read through and completely understood before making any attempt to fit this product.
3. Be wary of any changes to vehicle designs or other accessories that may conflict with the installation of this product.
4. Before drilling ensure that the area is clear of fuel, electrical & other components.
5. All holes drilled into the body panels shall have all burrs & swarf removed then coated with a suitable rust preventative paint.
6. For vehicles that require the bumper to be cut. Ensure cut out area is in correct position on the vehicle prior to cutting the bumper.
7. The high tensile fasteners supplied with this product were used to achieve the specified rating. If replacement is required ensure that fasteners of the same rating & quality are used. Contact an authorized **Trailboss** dealer if further information is required.
8. Ensure that all hardware is fastened to torque list below check fasteners on regular basis.
9. Tow bar load rating sticker provided with this product shall be conspicuously located on inside rear end of the driver's door. **(See diagram below).**
10. Trailboss recommends that you check your tow ball to ensure that it complies with the Australian standards **AS 4177.2.**
11. **PLEASE NOTE:** It is advised to remove your LUG or TBM when not actually towing so as to produce a clear view of the vehicles registration plate if obscured, and to also provide maximum available departure angle

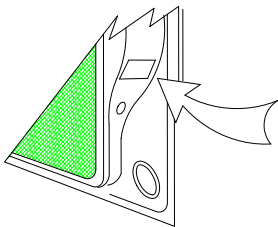

Place load rating sticker
inside driver's door here

FOR TRAILER TOWING PURPOSES ONLY
For towing capacity details please refer to vehicle owner's manual or to the manufacturer. Overloading can void your warranties.

RECOMMENDED ASSEMBLY TORQUE LISTING

Diameter	Grade 8.8 Bolt
M6	9.5 Nm
M8	21.7 Nm
M10	43.4 Nm
M12	77.3Nm
M14	146 Nm
M16	189.8 Nm

Tow bar Maintenance and Care.

Trailboss recommends that bolt torque's, as listed below, are routinely and regularly inspected and checked for correct tension. Replace any worn or defective parts.

We recommended to remove Tow Ball Mounts (TBM's, tongues or lugs) when not being used for any considerable length of time.

So as to avoid injury, when not towing it is suggested that the tongue, Pull Pin and R-clip are removed then stored in a safe, clean and dry place, away from excessive moisture.

Hitch Pull Pins and spring "R" clips are regularly checked for proper installation. Replace any worn or defective parts.

Cequent Customer Service

Ph: 1800 812 017 Fax: 03 9898 3299

Email: info@cequent.com.au

Post: PO Box 4050, Dandenong South VIC 3175

TRAILBOSS

Towbar Fitting Instructions
 To Suit **VOLVO XC60 DZ SERIES**
 Part Number **QTVO009L**
 Rating **2000/150 kg**

PLACE THESE INSTRUCTIONS IN THE VEHICLE'S GLOVEBOX AFTER INSTALLATION IS COMPLETED

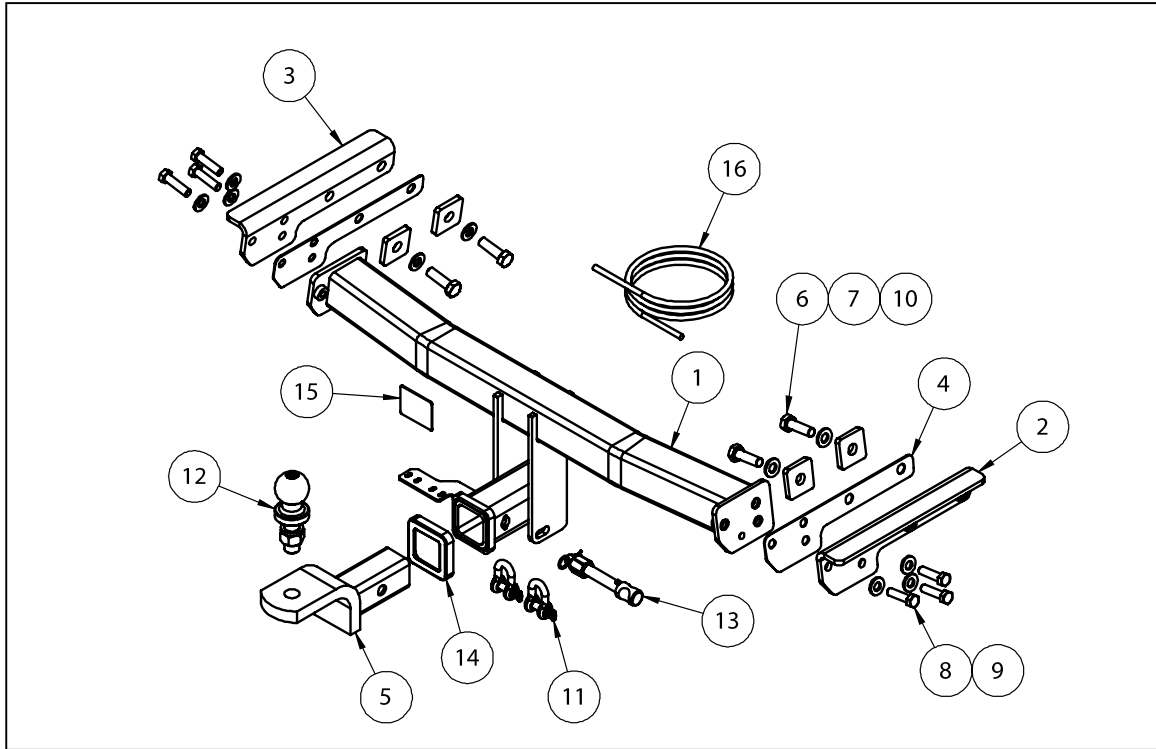



ITEM NO.	DESCRIPTION	QTY.
1	WELDED ASSEMBLY	1
2	SIDEARM ASSEMBLY-RHS	1
3	SIDEARM ASSEMBLY-LHS	1
4	SHIM PLATE	2
5	TBM ASSY	1
6	SET SCREW M14X45X2P G10.9	4
7	FT WASHER M14X28X3 Z/P	4
8	SET SCREW M12X45X1.25P G10.9	6
9	WASHER FLAT 1/2"X1 1/8"X1/8"	6
10	SPACER 8mm	4
11	10mm "D" SHACKLE	2
12	50mm TOWBALL	1
13	SILENT HITCH PIN - SILVER	1
14	HITCH BOX COLLAR COVER	1
15	ACRYLIC COMPLIANCE PLATE	1
16	WIRING LOOM	1

Cequent Customer Service
 Ph: 1800 812 017 Fax: 03 9898 3299
 Email: info@cequent.com.au
 Post: PO Box 4050, Dandenong South VIC 3175

TRAILBOSS

Towbar Fitting Instructions
To Suit **VOLVO XC60 DZ SERIES**
Part Number **QTVO009L**
Rating **2000/150 kg**

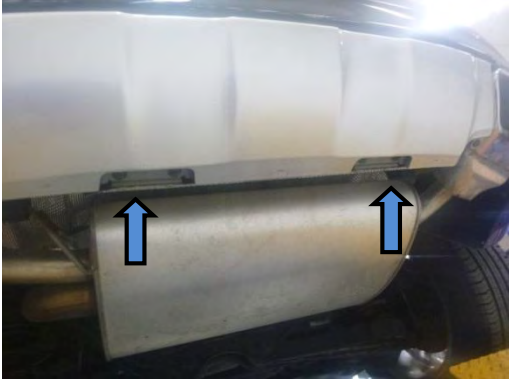
PLACE THESE INSTRUCTIONS IN THE VEHICLE'S GLOVEBOX AFTER INSTALLATION IS COMPLETED

<p>1. At underside of rear bumper, depending of variant, remove either 2 x Scrivets or 4 x hex head Screws.</p>	
<p>2. Remove Screw from under tailgate. Repeat for opposite side of vehicle.</p>	
<p>3. Remove 5 x Screws from inside rear wheel arch. Repeat for opposite side of vehicle.</p> <p>4. Carefully unclip and remove rear bumper. Disconnect parking sensor loom as required.</p>	

Cequent Customer Service
Ph: 1800 812 017 Fax: 03 9898 3299
Email: info@cequent.com.au
Post: PO Box 4050, Dandenong South VIC 3175

Towbar Fitting Instructions
To Suit **VOLVO XC60 DZ SERIES**
Part Number **QTVO009L**
Rating **2000/150 kg**

PLACE THESE INSTRUCTIONS IN THE VEHICLE'S GLOVEBOX AFTER INSTALLATION IS COMPLETED

5. Remove and discard 6 x hex head Screws from rear impact beam (3 per side); remove and discard rear impact beam.

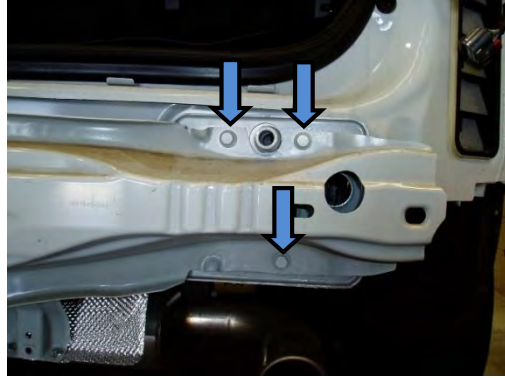

6. Remove hex head Screw securing exhaust mount bracket.

Repeat for opposite side of vehicle and lower rear section of exhaust.



7. Remove 4 x hex head Screws securing 2 x heat shield bracket. Lower heat shield for access to chassis rails.

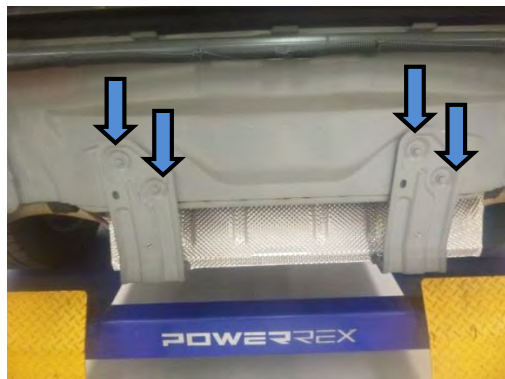

Towbar Fitting Instructions
To Suit **VOLVO XC60 DZ SERIES**
Part Number **QTVO009L**
Rating **2000/150 kg**

PLACE THESE INSTRUCTIONS IN THE VEHICLE'S GLOVEBOX AFTER INSTALLATION IS COMPLETED

- 8.** Insert sidearm assembly and shim plate into chassis rail.

Loosely secure to inside face of chassis rail using 2 x M14 hex head Screws, complete with 1 x flat Washer and 1 x Washer plate per Screw.

Repeat for opposite side of vehicle.



- 9.** Loosely secure welded towbar assembly to sidearm assemblies using 6 x M12 hex head Screws (3 per side), complete with 1 x flat washer per Screw.

- 10.** Tighten all fasteners to torques listed below:
M12: 125N.m
M14: 175N.m



Cequent Customer Service

Ph: 1800 812 017 Fax: 03 9898 3299

Email: info@cequent.com.au

Post: PO Box 4050, Dandenong South VIC 3175

Towbar Fitting Instructions
To Suit **VOLVO XC60 DZ SERIES**
Part Number **QTVO009L**
Rating **2000/150 kg**

PLACE THESE INSTRUCTIONS IN THE VEHICLE'S GLOVEBOX AFTER INSTALLATION IS COMPLETED

MY13 AND EARLIER

11. Identify centreline of bumper; create cut 90mm wide x 170mm tall, as measured on the outside face of the bumper, starting from the bottom edge of the bumper.

NOTE: Markout cuts and validate against vehicle prior to making cutouts.

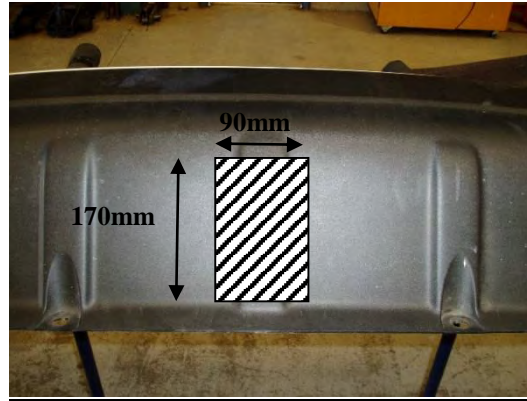

MY14 AND LATER

12. Identify centreline of bumper, create cut 90mm wide x 200mm tall, as measured on the outside face of the bumper, starting from the bottom edge of the bumper.

NOTE: Markout cuts and validate against vehicle prior to making cutouts.

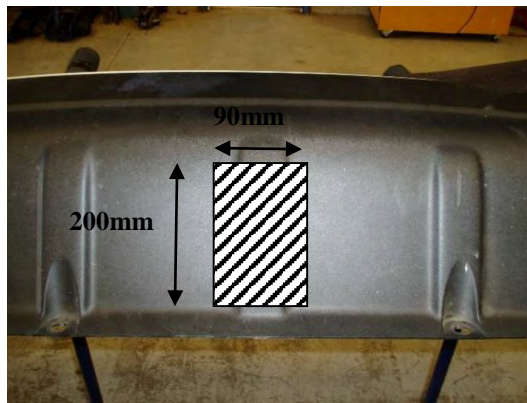

R-DESIGN BUMPER

13. Identify centreline of bumper, create cut 90mm wide x 210mm tall, as measured on the outside face of the bumper, starting from the bottom edge of the bumper.

NOTE: Markout cuts and validate against vehicle prior to making cutouts.

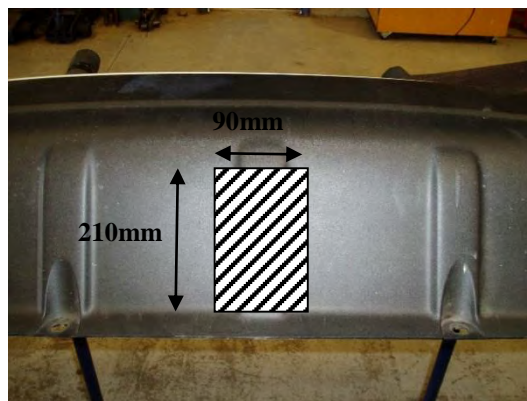

Cequent Customer Service

Ph: 1800 812 017 Fax: 03 9898 3299

Email: info@cequent.com.au

Post: PO Box 4050, Dandenong South VIC 3175



Towbar Fitting Instructions
To Suit **VOLVO XC60 DZ SERIES**
Part Number **QTVO009L**
Rating **2000/150 kg**

PLACE THESE INSTRUCTIONS IN THE VEHICLE'S GLOVEBOX AFTER INSTALLATION IS COMPLETED

ALL MODELS

14. Reinstall, exhaust, heat shield and bumper following steps 1 to 7, excluding step 5, in reverse order.

Cequent Customer Service

Ph: 1800 812 017 Fax: 03 9898 3299

Email: info@cequent.com.au

Post: PO Box 4050, Dandenong South VIC 3175



Wiring Loom Fitting Instructions
To Suit Volvo XC60
Part Number 100266-WL

Wiring Loom Installation Instructions

Volvo XC60
Part No: 100266-WL

Tail Harness Length Required: 1800mm
RPA Override Switch Part No: 04848 (If Fitted)

Wiring Loom Installation Time: Approx 40 Mins



Wiring Loom Fitting Instructions
To Suit Volvo XC60
Part Number 100266-WL

1. Remove the rear bumper
2. In the luggage compartment remove the floor carpet cover
3. Remove the storage compartment.
4. Remove the LHS access panel.
5. Remove the RHS access panel.
6. On the outside of the vehicle remove the LHS rear grommet.
7. Drill out the grommet hole to Ø31mm. File any rough or sharp edges and spray on rust inhibitor.
8. From outside of the vehicle mount the tail harness (tail length 1800mm) to the towbar mounting bracket using M4 fasteners (not supplied).
9. Route the tail harness through the previously drilled out hole.
10. Adjust the tail harness grommet into place ensuring it is seated correctly and secure the grommet with a cable tie (not supplied).
11. Route the trailer patch harness (P/No:100226-WL) along the rear of the vehicle towards the RHS and under RHS trim.
12. Route the trailer patch harness up towards the RHS access panel.
13. Disconnect the RHS tail light connector.
14. Connect the trailer patch harness to the RHS tail light assembly.
15. Connect the RHS tail light connector to the trailer patch harness.
16. Secure the trailer patch harness ground ring terminal to the existing grounding point located on the LHS below the side trim.
17. Connect the tail harness male 8-way connector to the trailer patch harness 8-way mating connector.
18. Disconnect the LHS tail light connector.
19. Connect the LHS tail light connector to the trailer patch harness.
20. Connect the patch harness connector to the LHS tail light assembly.
21. Insert the supplied 20-amp fuse into the upper slot of the add-a-fuse harness.
22. Insert the add-a-fuse into the vacant F5 fuse slot.
23. Connect the trailer patch harness to the add-a-fuse harness.



Wiring Loom Fitting Instructions
To Suit Volvo XC60
Part Number 100266-WL

24. If the fuse slot is already taken. Remove the vehicle fuse and insert it in the lower slot on the add-a-fuse harness.
25. Connect the 12-way trailer patch harness connector to the ECU.
26. Apply double sided tape to the ECU and mount it to the vehicle sheet metal.
27. Test the Trailer socket using a light board or multi-meter.
28. Secure the all harnesses using cables ties (not supplied).
29. Refit all removed parts and secure all fasteners.
30. Place instructions in glove box after fitment.



FITTING INSTRUCTIONS

Silent Anti-Rattle Hitch Pin (PR0001)

• These fitting instructions are supplied to ensure understanding of how the HITCH PIN should be fitted and used correctly.

• Once installed, we recommend **ALL** instructions are kept and placed in the vehicle glove box.

NOTE: Routine maintenance and inspection of the towbar & HITCH PIN is required. Regularly inspect for wear and check the tightness of the Hitch Pin. Follow instructions below to retighten the nut when necessary.

***Do not tow with your vehicle if the R CLIP or the HITCH PIN is loose or missing. Replacement parts are available from your Pro Series Distributor.**

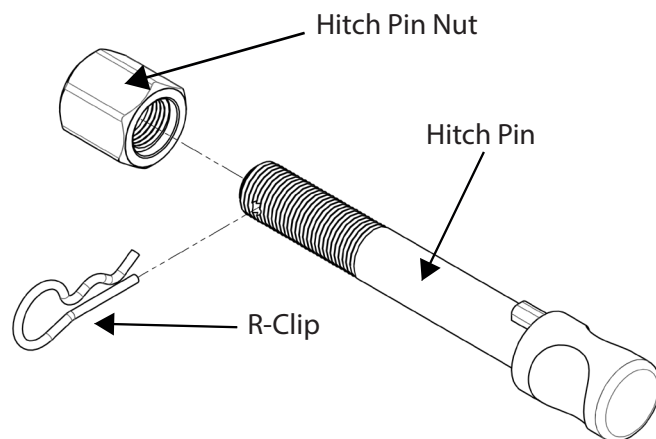

Fig 1. Silent Anti-Rattle Hitch Pin assembly

STEP 1

Insert Trailer Ball Mount (TBM) into towbar HITCHBOX, aligning hole in TBM SHANK with hole in HITCHBOX (Fig 2).

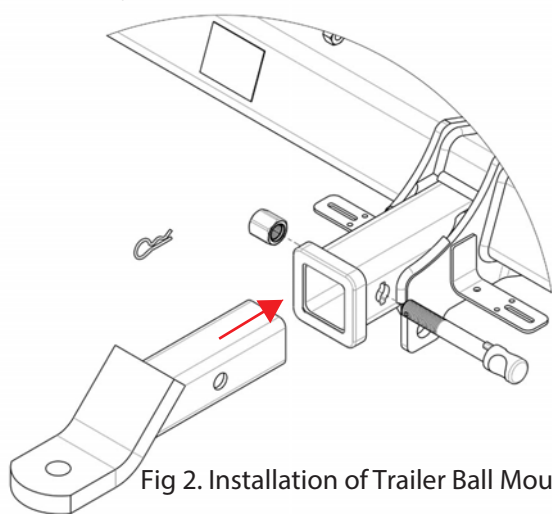

Fig 2. Installation of Trailer Ball Mount

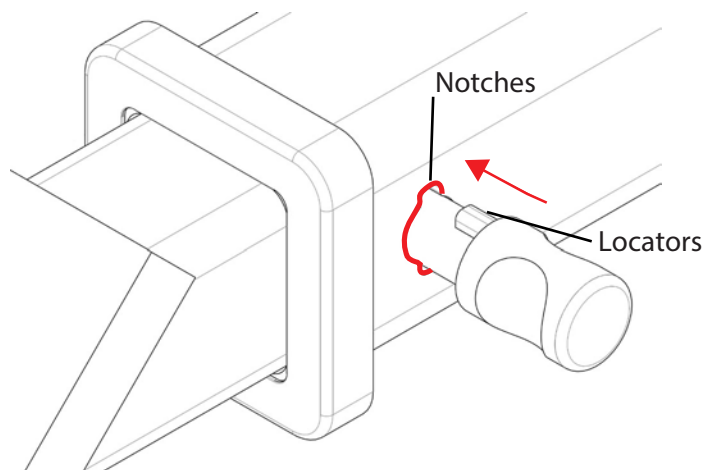

Fig 3. Silent Anti-Rattle Hitch Pin orientation

STEP 2

Insert HITCH PIN through hole in HITCHBOX and hole in TBM SHANK; ensure the LOCATORS are inserted into the NOTCHES in the HITCHBOX (Fig. 3).

STEP 3

Screw HITCH PIN NUT onto HITCH PIN ; tighten HITCH PIN NUT until finger tight, ensuring TBM is restrained from movement.

STEP 4

Tighten HITCH PIN NUT by turning nut a further 1/8th of a turn in the clockwise direction using a 24mm spanner (Fig. 4).

STEP 5

Install HITCH PIN R CLIP through the hole on the HITCH PIN (Fig. 1).

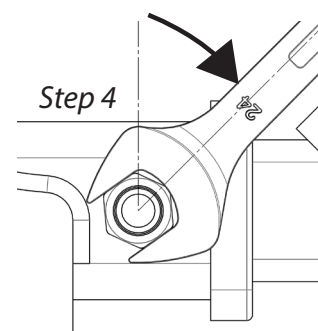

Fig 4. Tightening of Silent Anti-Rattle Hitch Pin Nut