

TRAILBOSS

Towbar Fitting Instructions
To Suit **ISUZU DMAX WITH STEP 06/2012 – ON**
Part Number **QTHD472L**
Rating **3500/350 kg**

PLACE THESE INSTRUCTIONS IN THE VEHICLE'S GLOVEBOX AFTER INSTALLATION IS COMPLETED

WARNING:

1. Do not, drill, cut, weld or otherwise modify the tow bar.
2. If you are using electric welding on a motor vehicle, **always** check that the vehicle is not equipped with electronic engine or instrument management equipment. Failure to do so could **destroy** any onboard computers. If in doubt, check with the vehicle's manufacturer.
3. The high tensile fasteners supplied with this product were used to achieve the specified rating. If replacement is required ensure that fasteners of the same rating & quality are used. Contact an authorised **Trailboss** dealer if further information is required.
4. If TBM is used in inverted position tow ball may make contact with rear tailgate when lowered, which could cause damage.

General:

1. Ensure all hardware items have been included refer to assembly diagram.
2. It is recommended that the instructions are read through and completely understood before making any attempt to fit this product.
3. Be wary of any changes to vehicle designs or other accessories that may conflict with the installation of this product.
4. Before drilling ensure that the area is clear of fuel, electrical & other components.
5. All holes drilled into the body panels shall have all burrs & swarf removed then coated with a suitable rust preventative paint.
6. For vehicles that require the bumper to be cut. Ensure cut out area is in correct position on the vehicle prior to cutting the bumper.
7. The high tensile fasteners supplied with this product were used to achieve the specified rating. If replacement is required ensure that fasteners of the same rating & quality are used. Contact an authorized **Trailboss** dealer if further information is required.
8. Ensure that all hardware is fastened to torque list below check fasteners on regular basis.
9. Tow bar load rating sticker provided with this product shall be conspicuously located on inside rear end of the driver's door. **(See diagram below).**
10. Trailboss recommends that you check your tow ball to ensure that it complies with the Australian standards **AS 4177.2.**
11. **PLEASE NOTE:** It is advised to remove your lug or tbn when not actually towing so as to produce a clear view of the vehicles registration plate if obscured, and to also provide maximum available departure angle
12. Pull Pin must be fit in down position.

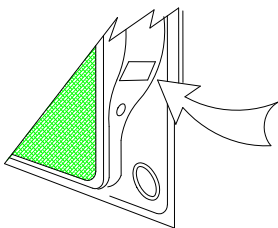

Place load rating sticker
inside driver's door here

FOR TRAILER TOWING PURPOSES ONLY
For towing capacity details please refer to vehicle owner's manual or to the manufacturer. Overloading can void your warranties.

RECOMMENDED ASSEMBLY TORQUE LISTING

Diameter	Grade 8.8 Bolt
M6	9.5 Nm
M8	21.7 Nm
M10	43.4 Nm
M12	77.3Nm
M14	146 Nm
M16	189.8 Nm

Tow bar Maintenance and Care.

Trailboss recommends that bolt torque's, as listed below, are routinely and regularly inspected and checked for correct tension. Replace any worn or defective parts.

We recommended to remove Tow Ball Mounts (TBM's, tongues or lugs) when not being used for any considerable length of time.

So as to avoid injury, when not towing it is suggested that the tongue, Pull Pin and R-clip are removed then stored in a safe, clean and dry place, away from excessive moisture.

Hitch Pull Pins and spring "R" clips are regularly checked for proper installation. Replace any worn or defective parts.

TRAILBOSS

Towbar Fitting Instructions
 To Suit **ISUZU DMAX WITH STEP 06/2012 – ON**
 Part Number **QTHD472L**
 Rating **3500/350 kg**

PLACE THESE INSTRUCTIONS IN THE VEHICLE'S GLOVEBOX AFTER INSTALLATION IS COMPLETED

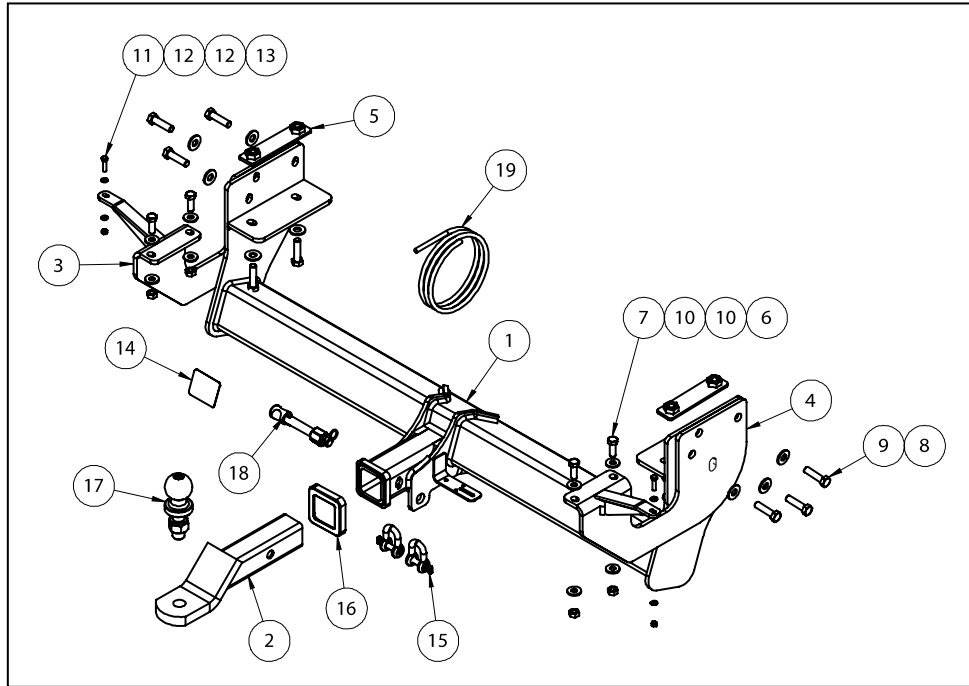

QTY.	DESCRIPTION	ITEM NO.
1	WELDED ASSEMBLY WITH STEP	1
1	TRAILER BALL MOUNT	2
1	LHS STEP BRACKET	3
1	RHS STEP BRACKET	4
2	NUT PLATE	5
4	HEX NUT M10x1.5	6
4	SET SCREW HEX HD M10x30x1.5P	7
10	WASHER FLAT M12	8
10	BOLT M12x45x1.25P	9
8	WASHR FT M10 x 25.4 x 3	10
2	SET SCREW M6x25x1P	11
4	WASHER FLAT M6x12.5x1.2	12
2	HEX NUT M6x1.0	13
1	COMPLIANCE LABEL	14
2	10mm "D" SHACKLE	15
1	HITCH BOX COLLAR COVER	16
1	50mm TOWBALL	17
1	SILENT HITCH PIN - SILVER	18
1	16 STRANDx0.3mm 7 CORE CABLE	19



Towbar Fitting Instructions
To Suit **ISUZU DMAX WITH STEP 06/2012 – ON**
Part Number **QTHD472L**
Rating **3500/350 kg**

PLACE THESE INSTRUCTIONS IN THE VEHICLE'S GLOVEBOX AFTER INSTALLATION IS COMPLETED

INSTRUCTION:

1. Disconnect rear registration light plug connection.
2. Remove 3 Bolts from LH & RH side step mounting brackets and remove step.
3. Remove Plastic Skin from step & remove holder step brackets. Loosely attach supplied brackets with 3 M10x25 Bolts with Flat Washers, Nut and 1 M8x35 Bolt with Flat washer and Nut for both RH & LH side.
Reattach Plastic Step Skin.
4. With assistance loosely bolt towbar to vehicle using Nut Plate and 2 M12x45 Bolts for both RH & LH side on the underside of the Chassis Rail.
5. Mate step to towbar with 3 M12 Bolts and Flat Washers for both RH & LH side.
6. Tighten all bolts to recommended assembly torque as shown in Page 1.
Refit Plastic Step Cover.
Reconnect rear registration light plug connection.

Note: Tighten step bracket to towbar whilst holding the step up so that sufficient clearance is present between step and hitch box.



Wiring Loom Fitting Instructions
To Suit Holden Colorado / Rodeo / D-Max MY12
Part Number 100055-WL

Wiring Loom Installation Instructions

Holden Colorado / Rodeo / D-Max MY12
Part No: 100055-WL

Tail Harness Length Required: 1200mm

Wiring Loom Installation Time: Approx 20 Mins



Wiring Loom Fitting Instructions
To Suit Holden Colorado / Rodeo / D-Max MY12
Part Number 100055-WL

1. Underneath the rear of the vehicle, locate and disconnect the LHS vehicle trailer break-out connector.
2. Secure the Tail Harness socket onto the towbar mounting bracket with fasteners.
3. Connect the Trailer Patch Harness (part no. 100055-WL) to the LHS break-out connector.
4. Route Tail Harness (length 1200mm) towards the Trailer Patch Harness and connect the Trailer Patch Harness to the Trailer tail Harness.
5. Secure the Trailer Patch Harness relays onto the interior vehicle sheet metal using tech screws.
6. Secure the vehicle patch harness and Tail Harness connectors using cable ties.
7. Test the Trailer socket using a light board or multi-meter.
8. Secure the all harnesses using cables ties (not supplied).
9. Refit all removed parts and secure all fasteners.
10. Place instructions in glove box after fitment.



FITTING INSTRUCTIONS

Silent Anti-Rattle Hitch Pin (PR0001)

• These fitting instructions are supplied to ensure understanding of how the HITCH PIN should be fitted and used correctly.

• Once installed, we recommend **ALL** instructions are kept and placed in the vehicle glove box.

NOTE: Routine maintenance and inspection of the towbar & HITCH PIN is required. Regularly inspect for wear and check the tightness of the Hitch Pin. Follow instructions below to retighten the nut when necessary.

***Do not tow with your vehicle if the R CLIP or the HITCH PIN is loose or missing. Replacement parts are available from your Pro Series Distributor.**

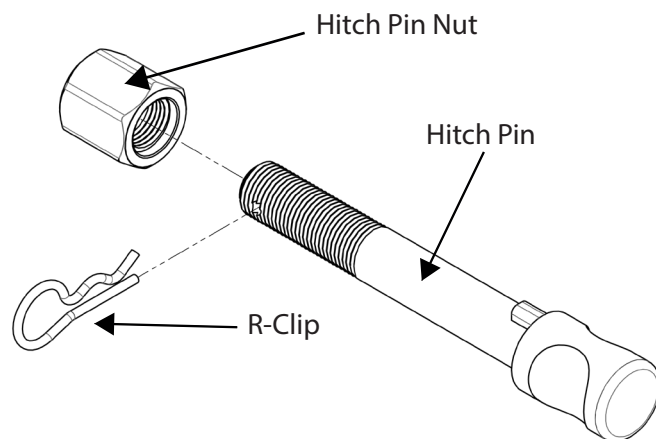

Fig 1. Silent Anti-Rattle Hitch Pin assembly

STEP 1

Insert Trailer Ball Mount (TBM) into towbar HITCHBOX, aligning hole in TBM SHANK with hole in HITCHBOX (Fig 2).

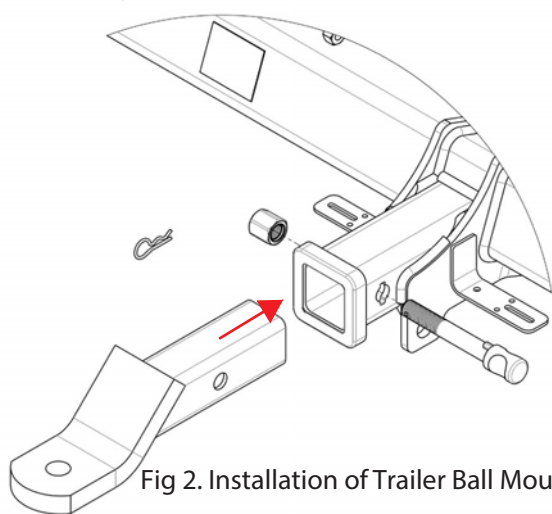

Fig 2. Installation of Trailer Ball Mount

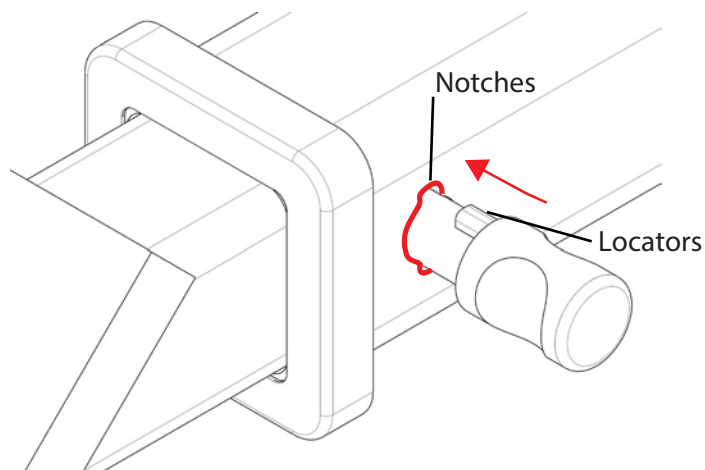

Fig 3. Silent Anti-Rattle Hitch Pin orientation

STEP 2

Insert HITCH PIN through hole in HITCHBOX and hole in TBM SHANK; ensure the LOCATORS are inserted into the NOTCHES in the HITCHBOX (Fig. 3).

STEP 3

Screw HITCH PIN NUT onto HITCH PIN; tighten HITCH PIN NUT until finger tight, ensuring TBM is restrained from movement.

STEP 4

Tighten HITCH PIN NUT by turning nut a further 1/8th of a turn in the clockwise direction using a 24mm spanner (Fig. 4).

STEP 5

Install HITCH PIN R CLIP through the hole on the HITCH PIN (Fig. 1).

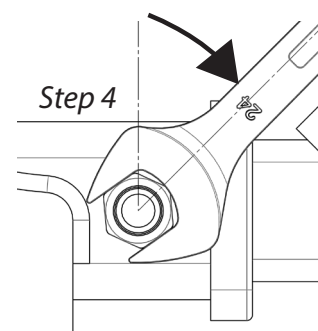

Fig 4. Tightening of Silent Anti-Rattle Hitch Pin Nut